

# GUIDELINES FOR SURVEYS



ASSOCIATION OF ONTARIO LAND SURVEYORS

# **GUIDELINES FOR SURVEYS**

## **CONTENTS**

### **GUIDELINES FOR:**

<b>A</b>	<b>Field Notes</b>
<b>B</b>	<b>Sketches</b>
<b>C</b>	<b>Construction</b>
<b>D</b>	<b>Control Surveys</b>
<b>E</b>	<b>Use of Total Station and Radial Methods for Legal Surveys</b>

**7/84**

Revised 3/92 to include Item "E".

**GUIDELINES FOR FIELD NOTES**

1. Section 4(1) of PART I of the Surveys Act states that every surveyor shall make and preserve exact and regular field notes of all his surveys and shall keep a proper record and index of all such field notes. Such field notes should contain a clear and detailed account of everything found, observed and done in the field in the course of a survey and relevant to it and should show:
  - a) a North arrow
  - b) designation of geographic areas (subdivision units) being surveyed and adjacent thereto
  - c) a date on each page and the file number
  - d) the type and identification of all measuring equipment used (EDM or chain)
  - e) the identification (names or initials) of the party chief and assistants
  - f) weather conditions
  - g) the entry of all observations or measurements, including slope, tension, temperature and tape correction, as required
  - h) an adequate description of all evidence found, including the identification marking if legible, all monuments set or restored and every permanent structure referencing monuments
  - i) offset lines and traverse lines identified

- j) names and widenings of streets
  - k) annotation of instrument stations, interline points, points of intersection and site stations, etc.,
  - l) whether angles and distances have been set or measured
  - m) reference to records of field calculations
  - n) dimension arrows for distances and angle measurements where required
2. After the field survey has been completed, entries on field notes found to be incorrect should not be erased, but stroked out in such a manner that they remain legible, but are obviously discarded.
  3. Field notes should be recorded at the time of observation.
  4. Data added to field notes on a date other than that recorded on the page should be so identified.
  5. Pages should be numbered and each page should indicate the total number of pages used.
  6. A field note report should include:
    - a) record of all oral evidence obtained;
    - b) any discrepancy or assessment of conflicting evidence
  7. Where it is deemed necessary to re-draw field notes, the original field notes should be retained and attached to the copies.

8. Where field data are recorded by any automated or semi-automated data gathering device, including voice recordings, these data should be verified and transcribed onto a permanent, visually readable format attached to the field notes before the data are incorporated into a final survey.

## GUIDELINES FOR SKETCHES

1. Sketches should not be prepared on the pre-printed forms used for Building Location Surveys or Plans of Survey which contain the legends, certificates, etc., pertinent to surveys.
2. Sketches should indicate in their title blocks, the purpose of the sketch, for example:
  - a) Building Permit Application
  - b) Severance Application
3. The geographic location of the parcel should appear as part of the sketch and not in the title block.
4. The following "CAUTION NOTE" should appear prominently on the sketch.

### **"CAUTION**

**This is not a plan of survey and shall not  
be used for transaction or mortgage purposes.**

**This sketch is protected by copyright."**

5. A "Note" should appear on all sketches indicating the source of dimensions and information shown on the sketch and noting if they are not obtained from survey.
6. The sketch should contain a statement that each copy must be embossed with the surveyor's seal.
7. The sketch should not be signed unless required by an approving agency.

# SKETCH

PREPARED FOR BUILDING PERMIT APPLICATION

SCALE 1:250



## CAUTION

THIS IS NOT A PLAN OF SURVEY AND SHALL NOT BE USED FOR TRANSACTION OR MORTGAGE PURPOSES.

© THIS SKETCH IS PROTECTED BY COPYRIGHT

METRIC  
DISTANCES SHOWN ON  
THIS PLAN ARE IN METRES  
AND CAN BE CONVERTED  
TO FEET BY DIVIDING BY  
0.3048

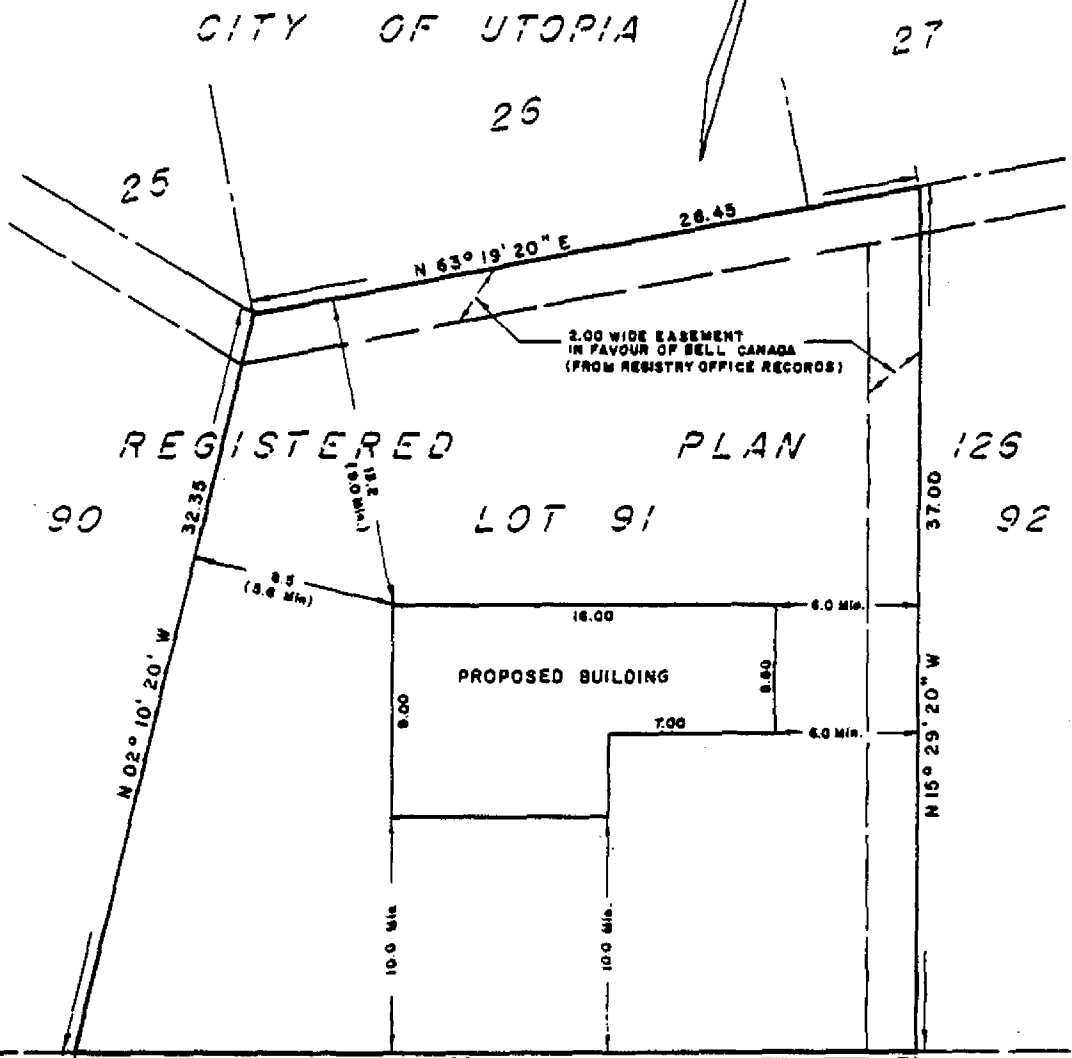

### SHORT STREET

"THIS IS NOT AN ORIGINAL COPY UNLESS EMBOSSED WITH SEAL"

DATE

### NOTE

LOT DIMENSIONS ARE AS SHOWN ON REGISTERED PLAN 126 AND HAVE NOT BEEN VERIFIED BY SURVEY.  
PROPOSED BUILDING POSITIONED BY CALCULATION, NOT BY ACTUAL SURVEY.

"SIGNATURE OPTIONAL"  
\_\_\_\_\_  
ONTARIO LAND SURVEYOR  
AND/OR COMPANY

# SKETCH

PREPARED FOR SEVERANCE APPLICATION

SCALE 1:300



## CAUTION

THIS IS NOT A PLAN OF SURVEY AND SHALL NOT BE USED FOR TRANSACTION OR MORTGAGE PURPOSES.

© THIS SKETCH IS PROTECTED BY COPYRIGHT

METRIC  
DISTANCES SHOWN ON  
THIS PLAN ARE IN METRES  
AND CAN BE CONVERTED  
TO FEET BY DIVIDING BY  
0.3048

### TOWN OF HAMLET

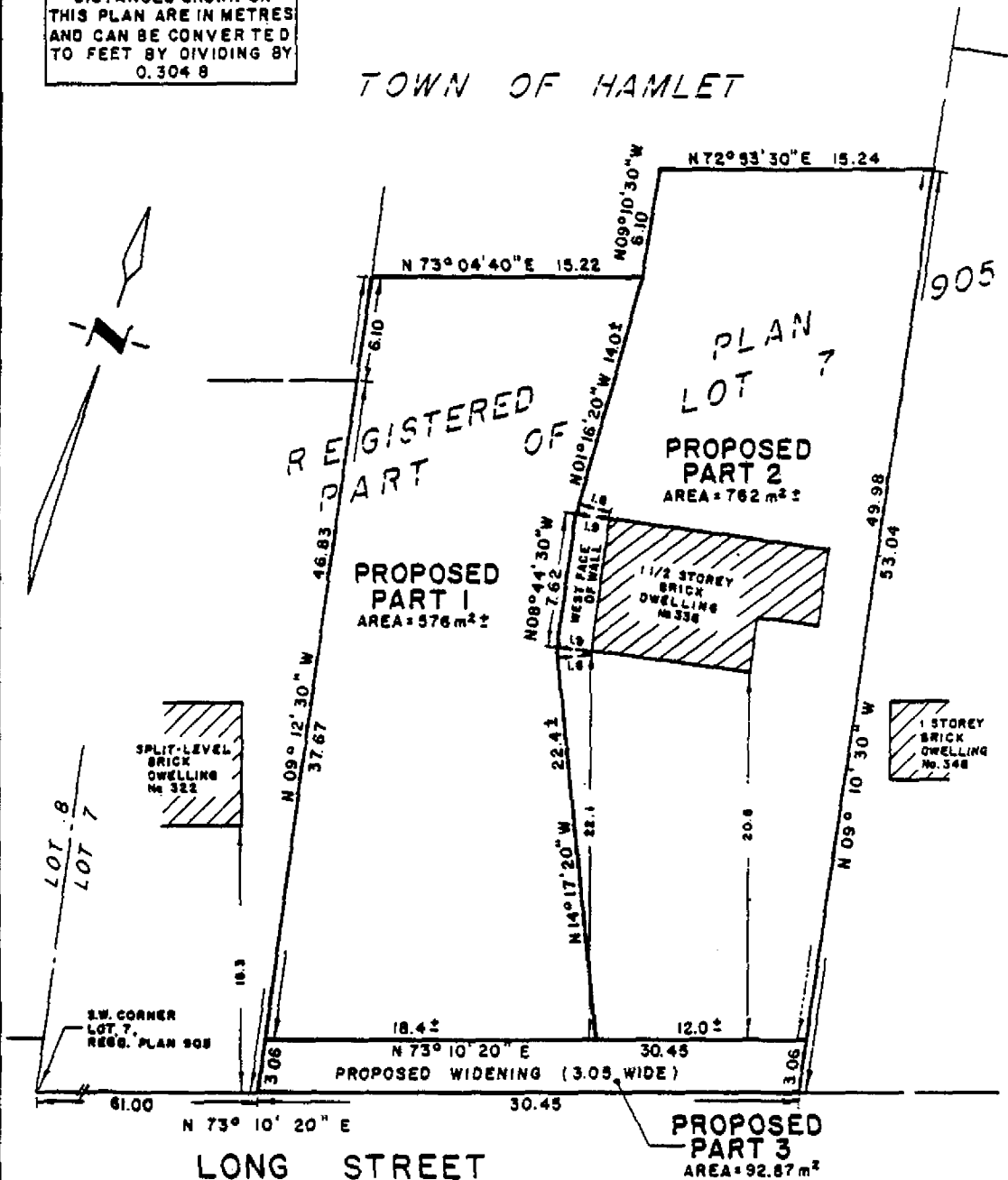

"THIS IS NOT  
AN ORIGINAL COPY  
UNLESS  
EMBOSSED WITH  
SEAL"

DATE \_\_\_\_\_

**NOTE**  
THIS SKETCH IS PREPARED FROM COMPILED AND CALCULATED INFORMATION, NOT FROM AN ACTUAL SURVEY.  
DISTANCES SHOWN HAVE NOT BEEN VERIFIED.

"SIGNATURE OPTIONAL"  
\_\_\_\_\_  
ONTARIO LAND SURVEYOR  
AND / OR COMPANY



**GUIDELINES FOR CONSTRUCTION LAYOUT,  
TOPOGRAPHIC AND SITE (ARCHITECTS) SURVEYS**

Procedural Guidelines

**1. RESEARCH**

The surveyor should:

- a) Obtain from the client the approved plans and specifications together with any available pertinent information regarding the ownership, existing topography and proposed use of the site.
- b) Make a registry office search for the property noting any easements, rights-of-way, or other registered encumbrances such as prescriptive rights, use of driveways or other encroachments.
- c) Attend at the offices of any utilities or municipal public works departments and obtain information regarding installations on or in the ground in the vicinity of the site. Obtain technical data concerning such utilities and make arrangements to have them located and marked (if not evident) immediately prior to the commencement of the work.
- d) Obtain a copy of the up-to-date zoning by-law and verify compliance by the proposed construction. If required or if there is any doubt, attend at the planning/building department of the municipality for interpretation or approval of proposed plans.
- e) If a legal survey does not exist ensure that one will be available or arrange to prepare the same before layout begins or a site survey is prepared, showing precise locations of structures or physical features.

- f) Obtain geodetic vertical control data from published sources.
- g) Discuss the project thoroughly with the client, or his authorized agent, making written notes of the decisions made or instructions given with regard to the location of control points, bench marks, depths-of-cut and any other details and the method of showing the same on the site, marked on construction drawings or a separate plan, or in a report. Determine whether Imperial or Metric units are to be used.
- h) When an OLS enters into an arrangement to have members of his staff work for a client other than under his direct supervision, the OLS or authorized OLS firm must enter into a written contract with the client. This contract must clearly specify that the OLS is not responsible or liable for such work performed by his employees under the sub-contract.
- i) Include all pertinent details in a written contract with the client and signed by the client.

## 2. ANALYSIS OF RESEARCH AND PLANNING

The surveyor should:

- a) examine thoroughly and analyze all data obtained for obvious inconsistencies with known standards or regulations. This should include mathematical checks to ensure that construction, as proposed, is possible.
- b) Bring any observed inconsistencies to the attention of the client immediately. Do not continue work until receiving written instructions from the client.

- c) Plan the procedures to be followed in the field and give clear directions to field party chief or supervisor. Stress the importance of following good field procedures and emphasize particular areas of concern. Point out the location of necessary verification areas.

### 3. FIELD INVESTIGATION, LAYOUT AND SURVEY

- a) After completion of boundary survey or with an up-to-date survey, determine the monuments, lines or objects indicated by the construction documents as the intended references for the horizontal and vertical datums.

In the case of topographic or site surveys, search for and identify the boundaries of the project as defined by survey monuments or other structures as required.

- b) Establish horizontal control for construction layout setting reference monuments as required.

For topographic or site surveys establish a reference grid or pattern of sufficient density to obtain elevations or contours to the standard required.

- c) Establish vertical control as required including additional bench marks, "off-site", for safety during excavation and earthmoving.
- d) Take sufficient check measurements to other boundaries or existing buildings of known position to ensure that no blunders or gross errors have been made.

N.B. More precise checks should be made immediately if excavation or construction is imminent. Otherwise checking in the relatively calm atmosphere of the office is preferred.

Methods of verification should include some or all of the following and any others that will assist in avoiding errors:

- Measuring diagonals to check for both proper size and rectilinearity
  - Check random angles and distances between 3 points and compare to calculated angles and distances
  - Measurement to adjacent buildings or property lines on the side remote from the side layed-out from
  - Tie to centre line of road or sidewalk if their positions are known
  - Re-level vertical control points
  - Obtain elevation of excavation and compare to centre line of road for sewer fall.
- e) Record all information on appropriate field note forms including all verifications made.
- f) Bring any errors, inconsistencies or potential problems to the attention of the client immediately. To avoid delay report verbally followed by a written report. Do not provide excavation or other layout data until authorized in writing by the client.

- g) In the event of the discovery of a disagreement with the work of any other person on the site, notify the client immediately.
- h) For topographic and site surveys locate and identify on the plan all required information including easements, rights-of-way, encumbrances and prescriptive easements or rights-of-way.

#### 4. PUBLICATION AND REPORT

- a) Publish all required information in the form and on such material as agreed to with the client.
- b) A written report outlining the scope of the work and any problems encountered, including their resolution, should be provided to the client.

## Technical Guidelines

### 1. MEASUREMENTS

- a) Measurements should be taken to a precision compatible with the construction or other tolerances.
- b) All measurements should be recorded and shown in the field notes or on any plan or report to a number of significant figures representative of the precision of the work.

### 2. MONUMENTS

- a) Construction layout monuments should be of a type and character providing a degree of permanency consistent with the terrain, physical features and intended use.

The use of standard iron bars or iron bars as construction layout monuments should be discouraged to avoid confusion with boundary markers.

- b) Key monuments should be witnessed in such a manner as affords easy and accurate replacement. Such methods might include:
  - Projection of control lines to concrete curbs and sidewalks marking a reference distance with a cut mark
  - Similar projection to specific locations on existing structures
  - Positioning of points on projections of control lines in areas not subject to construction.

- c) Stakes used to record construction layout data should be identified as to their application.
- d) Determination of vertical information should be made using geodetic datum unless otherwise clearly understood arrangements have been made. Reference should be to published information.

No intermediate sights should be taken unless the height-of-instrument has been verified by including at least one turning point in the level loop or the elevation is carried to a different bench mark.

- e) "Local" or "temporary" bench marks should only be turning points in a checked loop. Bench marks should only be placed on points that have some permanence, such as concrete porches or floors of buildings. Fire hydrants and nails in utility poles should be avoided as they are subject to change by the utility, and may be potential safety hazards.
- f) If a number of "depths-of-cut" have been determined it is desirable to re-level the same in an independent manner.

Random checks on elevations determined in topographic surveys will be found of value and should include at least one point redetermined for each group of intermediate sights taken at each H.I.

- g) Party chief or field supervisor to make a visual inspection before leaving site to note any obvious inconsistencies in notes or layout.

### 3. FIELD NOTES

- a) Record all pertinent information, measurements and observations made in the field during the course of the survey or construction layout on an appropriate field note form.



## GUIDELINES FOR RELATING CADASTRAL SURVEYS TO CONTROL SURVEY NETWORKS

### 1.0 INTRODUCTION

The Association of Ontario Land Surveyors has prepared and published these Guidelines to standardize the orderly and systematic integration of cadastral surveys into the provincial horizontal control survey network. The Guidelines shall only be applied in those areas where a reasonably dense horizontal control survey network is in place.

The Guidelines must be read in conjunction with "Ontario Specifications for Horizontal Control Surveys, 1979 (OG79)". OS79 and OG79 include statistical concepts and definitions concerning the classification of control survey networks together with the procedures to be followed for performing reconnaissance and network design.

The "Specifications and Recommendations for Control Surveys and Survey Markers" published by the Surveys and Mapping Branch, Ottawa, provides additional information concerning the above matters.

It should be borne in mind that these Guidelines are not static. They will require frequent updating, particularly in the initial years, to ensure that they reflect current survey concepts and technology.

The Council of the Association of Ontario Land Surveyors has an obligation to govern the profession and practice of surveying in accordance with the objectives of the Association. One of these objectives is "to establish and maintain standards of knowledge and skill among its

members". These Guidelines are published as one of the documents required to fulfill this objective.

## 2.0 DEFINITIONS

In these Guidelines:

- 2.1 **CONTROL SURVEY STATION** means a point in a horizontal control survey network, referenced by a monument, for which the geographic position has been determined to at least third order accuracy in accordance with OS79.
- 2.2 **HORIZONTAL CONTROL SURVEY** means a Geodetic survey made for the purpose of establishing the geographic position of points on the surface of the earth relative to the geodetic horizontal control network.
- 2.3 **INTEGRATED POINT** means a cadastral survey point which has been coordinated as part of an integrated survey.
- 2.4 **INTEGRATED SURVEY** means a cadastral survey, the points of which have been coordinated relative to the geodetic horizontal control network, in compliance with the classification standards outlined in Section 3.0 of these Guidelines.
- 2.5 **UNIQUE IDENTIFIER** means a unique encoded label given to each integrated point. The label consists of a string of symbols for recording:
- a) The Registry office or division number;
  - b) A letter identifying the type of plan;
  - c) The registered number of the plan of survey in which the integrated point is located;

- d) The ordinal number of the point within the integrated survey as designated on the plan.

### 3.0 CLASSIFICATION OF INTEGRATED SURVEYS

A cadastral survey and the monuments contained therein will be classified as an integrated survey and integrated monuments respectively, without regard to the method of survey, according to the length of the semi-major axes of the 95% confidence region of its coordinates relative to other monuments in the survey, to adjacent horizontal control stations and to other integrated monuments.

The length of the semi-major axis of the 95% confidence region, after adjustment, must be no greater than the value for  $r$ , where  $r = 20d$ , and  $r$  is expressed in centimetres and  $d$  is the distance between neighbouring points expressed in kilometres. Notwithstanding the length of the semi-major axis, a monument shall be classified as an integrated monument providing  $r$  is no greater than 2 cm. Thus, in order for a cadastral monument to be classified as integrated, the semi-major axis of the 95% confidence region must, after adjustment, be no greater than  $20d$  cm. or 2 cm. whichever is greater in relationship to the neighbouring horizontal control and integrated monuments.

### 4.0 USE OF SI (METRIC) UNITS

Published information for integrated surveys shall be in SI (Metric) Units.

### 5.0 PROCEDURES

- 5.1 A cadastral survey is integrated when it is connected to all nearby horizontal control stations (preferably

one on each side of the survey) and all adjacent integrated monuments. However, where the survey is to further subdivide a previously integrated survey the ties to control stations need not be made providing the conditions stated in Section 5.2 have been met.

- 5.2 Before using an existing control survey monument or an existing integrated monument, sufficient checks must be taken to ensure that it has not been disturbed.
- 5.3 The instrumentation and procedures used for angular observations shall be in accordance with recommended procedures for fourth order surveys as outlined in OG79.
- 5.4 Distance measured by electronic distance measuring systems shall be made in accordance with manufacturer's specifications.

The guidelines for the distance measurements are:

Standard deviation of the mean for traverses - 40 ppm

Standard deviation of the mean for trilateration - 20 ppm

- 5.5 Angular Checks - the suggested maximum allowable angular misclosure:
  - a) between horizontal control azimuths is - 20 n seconds
  - b) for self-closing loops is - 12 n seconds

where n is the number of angles involved.

- 5.6 Positional Checks - the suggested maximum allowable positional misclosure:
- a) between horizontal control stations as 1 part in 8,000 or 2 cm., whichever is greater;
  - b) for self-closing loops is 1 part in 10,000 or 2 cm., whichever is greater.
- 5.7 The elevation of each station shall be determined to an accuracy sufficient to ensure that the accuracy of measured distances between stations is not significantly affected by the process of reducing the measured distances to mean sea level.
- 5.8 The computer program used for the processing of the data shall be fully documented and capable of:
- (i) Listing the input data together with the observed distances, directions, and azimuths and the weights and standards deviations of all the observations;
  - (ii) Performing a least squares adjustment based on weighted observations;
  - (iii) Computing plane coordinate values to a precision of at least 1 mm and displaying them in a plane coordinate system to at least 1 mm;
  - (iv) Providing at least the following:
    - adjustment report including residuals;
    - the variance factor is computed from the adjustment results;

- the relative error ellipses (95% confidence regions) between monuments.

NOTE: A least squares adjustment is not required for any integrated monument located within a subdivision of land providing the procedures and equipment used in setting such integrated monuments yield the accuracy specified in Section 3.0. The following example may be used as a guideline to ascertain the accuracy of such integrated monument.

Example of simple computation of confidence region for a hanging line:

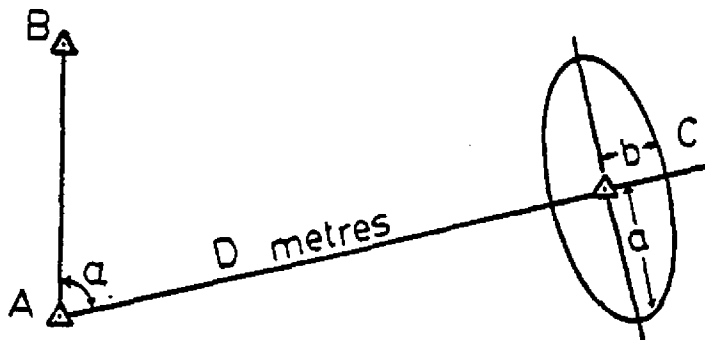

In the above figure if the procedures and equipment used to measure angle 1 yields a standard deviation of " " for angle 1 then the 95% confidence region of the position of C relative to A would have a semi-axis ("a") perpendicular to AC of:

$$2.5 \times \sin \quad " \times D \text{ metres.}$$

If the procedures and equipment used to measure the distance D yield a standard deviation of " " metres then the 95% confidence region of the position of C relative to A would have a semi-axis ("b") in the direction of AC of:

$$2.5 \times \quad \text{metres}$$

The semi-major axis of the 95% confidence region of C is the larger of a and b.

Note that the calculation of standard deviations for both angular and distance measurements shall include the following:

- machine error;
- operator error (e.g. set up error at both instrument and target stations);
- number of sets measured
- constant weight factor if applicable.

## 6.0 SURVEY PLANS

6.1 The plans shall show a note as follows:

"Bearings hereon are grid bearings and are derived from (specify the two or more horizontal control or integrated monuments used for bearing control) and are referred to the central meridian (state the degree of longitude) of zone (state the zone number) and are based on the 19\_\_ adjustment."

6.2 The distances shown on a plan shall be adjusted, horizontal ground distances and the following note shall appear on the plan:

"Distances shown hereon are adjusted, horizontal ground distances".

6.3 The horizontal control stations to which an integrated survey has been tied shall be identified on the plan together with the coordinate values thereof.

6.4 The combined scale factor applicable to the survey shall be shown in a conspicuous place on the plan.

6.5 The plan shall show a note as follows:

"This is an Integrated Survey Plan."

## 7.0 SURVEY RETURNS

The following survey returns shall be submitted to the client or retained in the surveyor's file. Specific instructions by the client may require additional items to those listed below.



- 7.1 A list of the items comprising the returns.
- 7.2 A report which provides a brief resume of the work performed and outlines the following:
  - (i) Any unusual problems or difficulties encountered;
  - (ii) Any significant deviation from these guidelines together with an explanation. The explanation shall include any inconsistencies in the final adjustment;
  - (iii) An explanation of how the weighting of measurements was derived;
  - (iv) A list of stations held fixed in the final adjustment together with the source of the fixed values.
- 7.3 A computer listing of input as well as output of all computations, as listed in Section 5.8, together with an explanation of any inconsistencies.
- 7.4 A plan as required according to the Act or Acts governing the particular cadastral survey, together with the information indicated in Section 6.0.

EXAMPLES OF ACCEPTABLE TIES OF  
CADASTRAL POINTS TO HORIZONTAL  
CONTROL MONUMENTS

- ▲ Fixed Horizontal Control Point
- △ Project Control Point
- New Cadastral Point
- Previously Integrated Cadastral Point
- Traverse Point
- A Angular measurement required to tie cadastral monuments into horizontal control
- + Distance measurement required to tie cadastral monuments into horizontal control

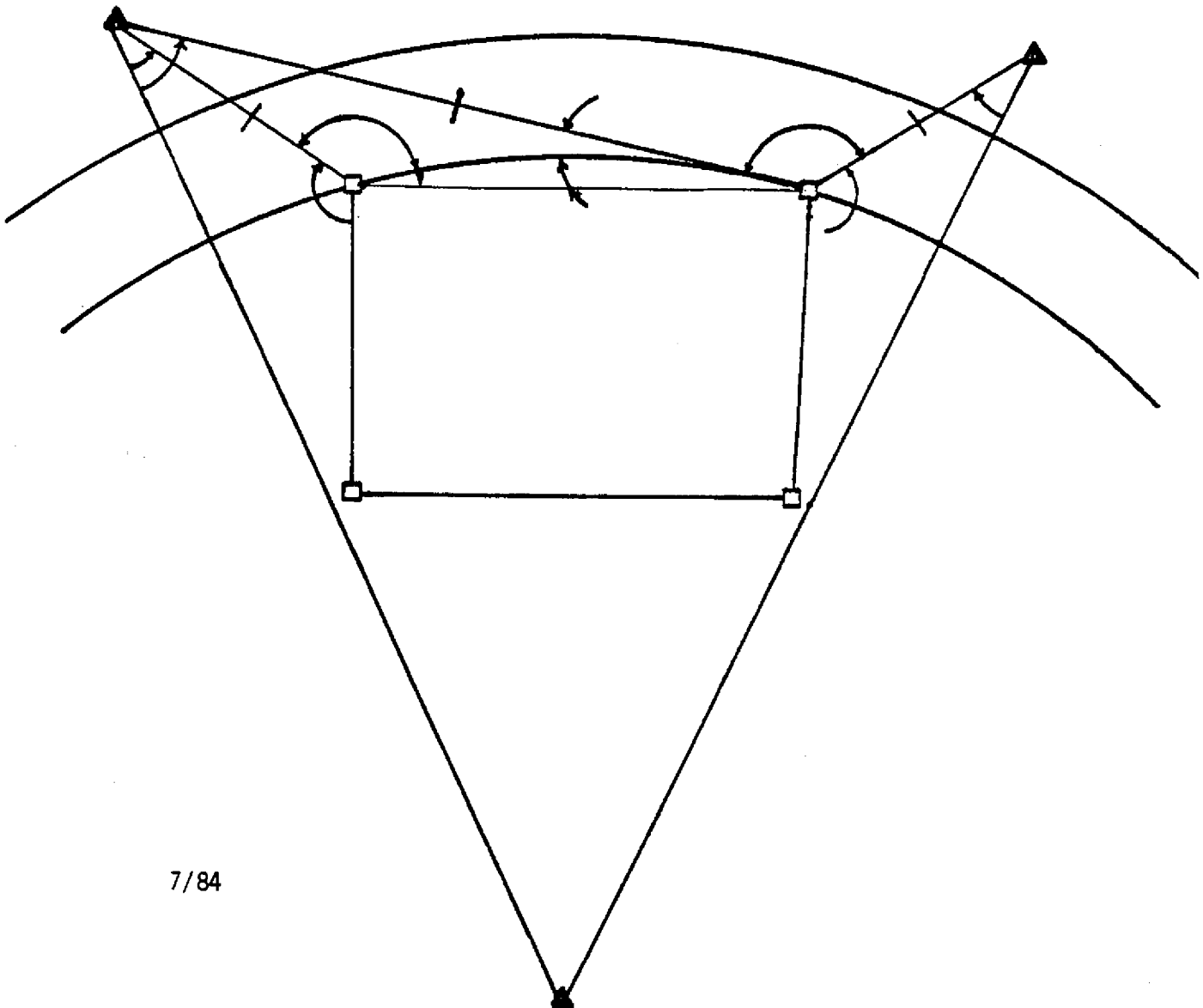

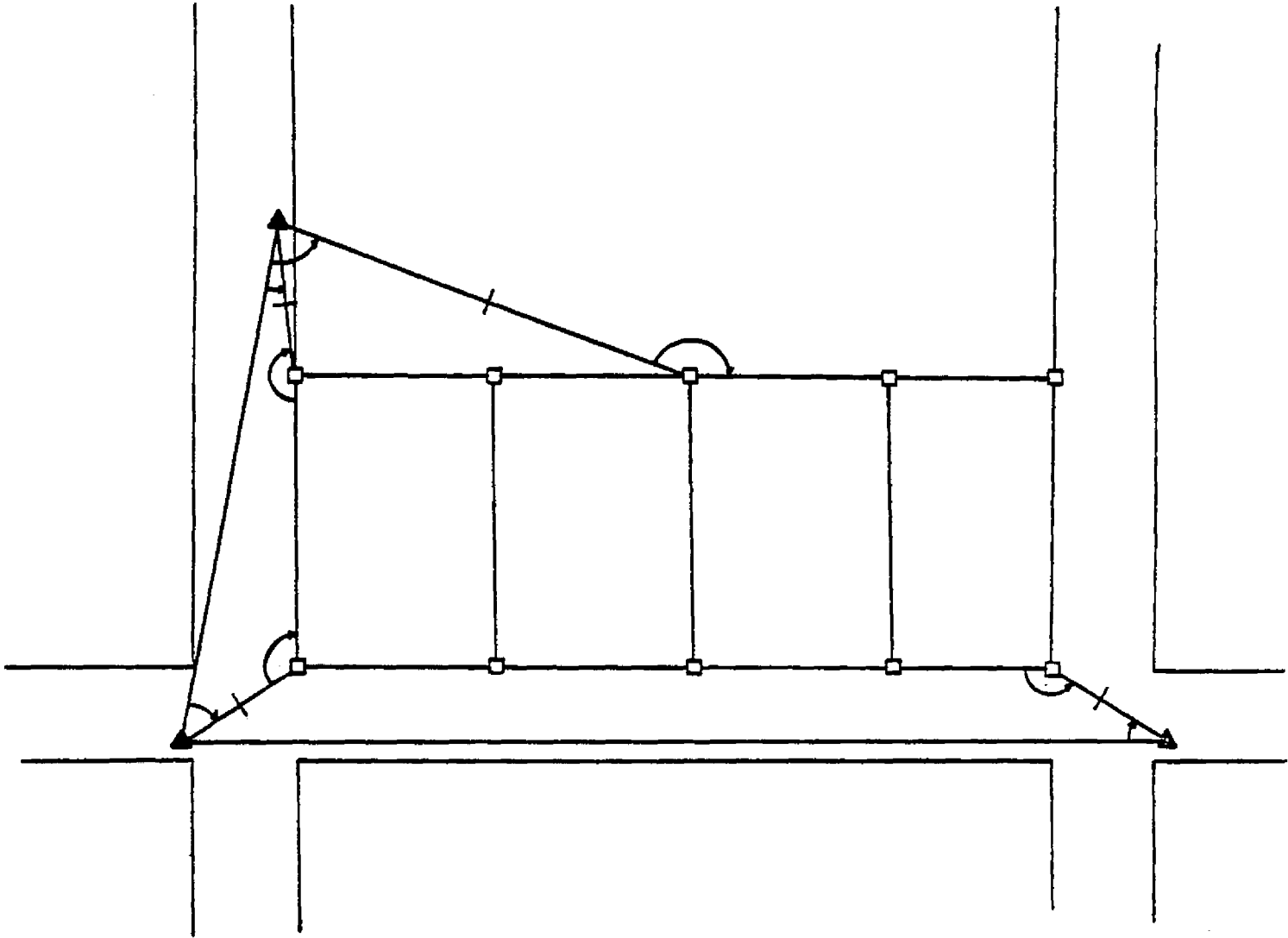

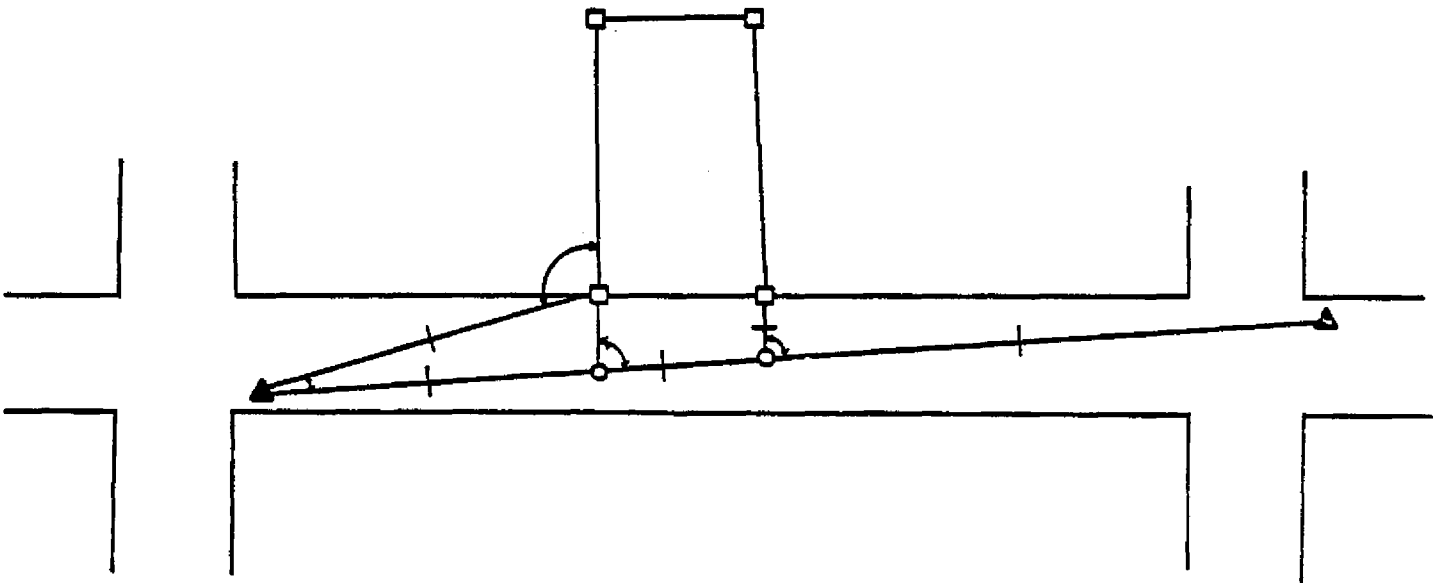

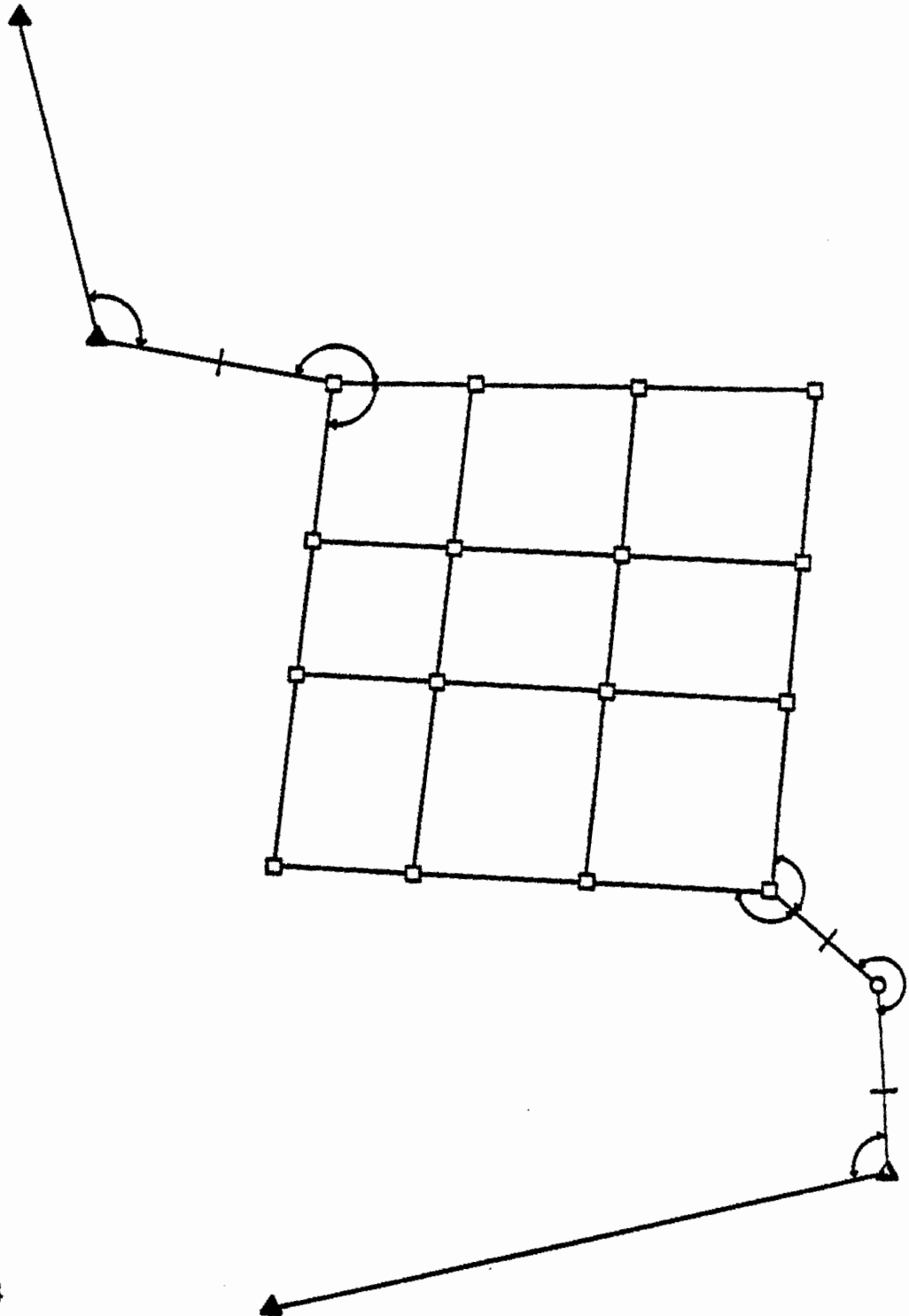

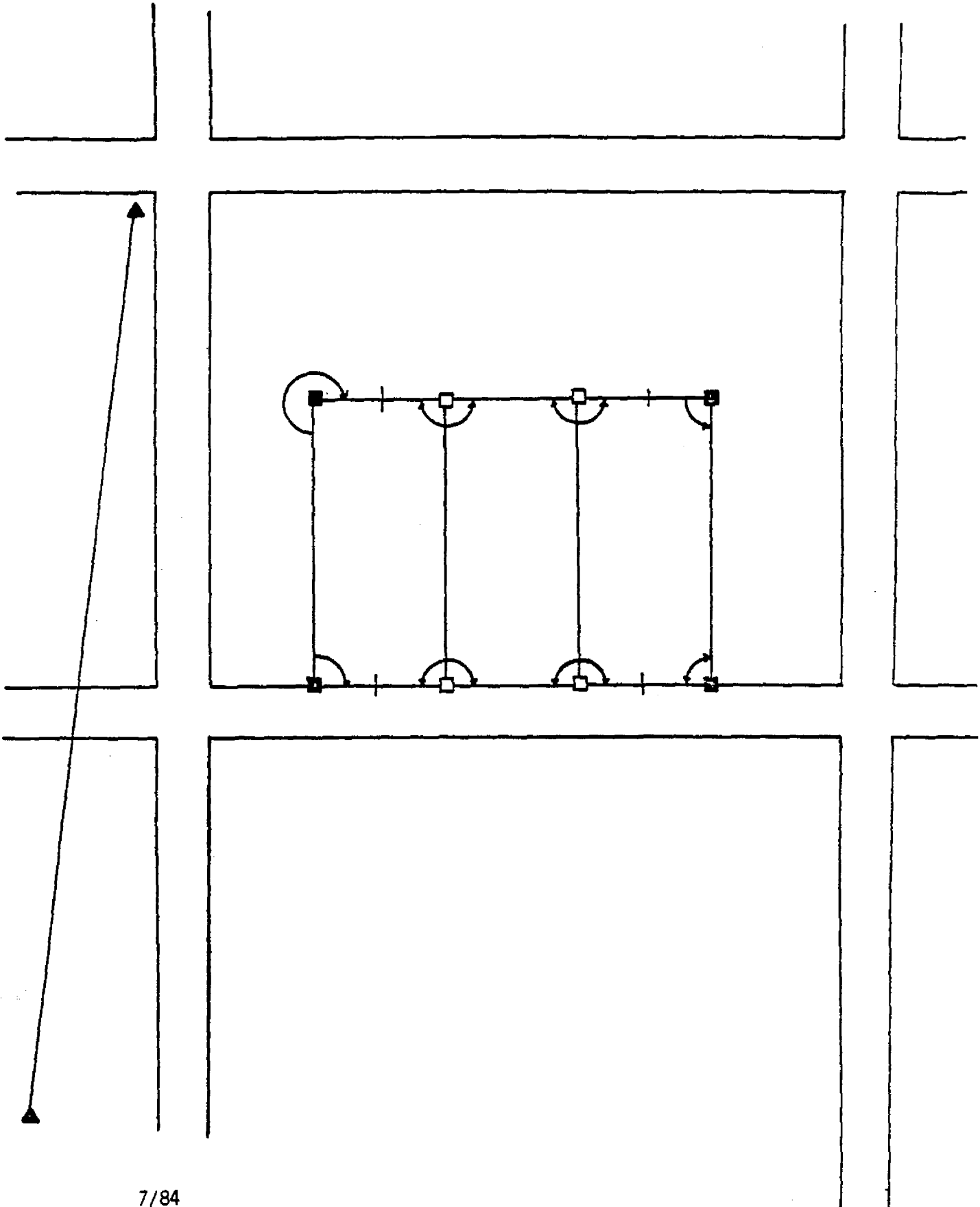

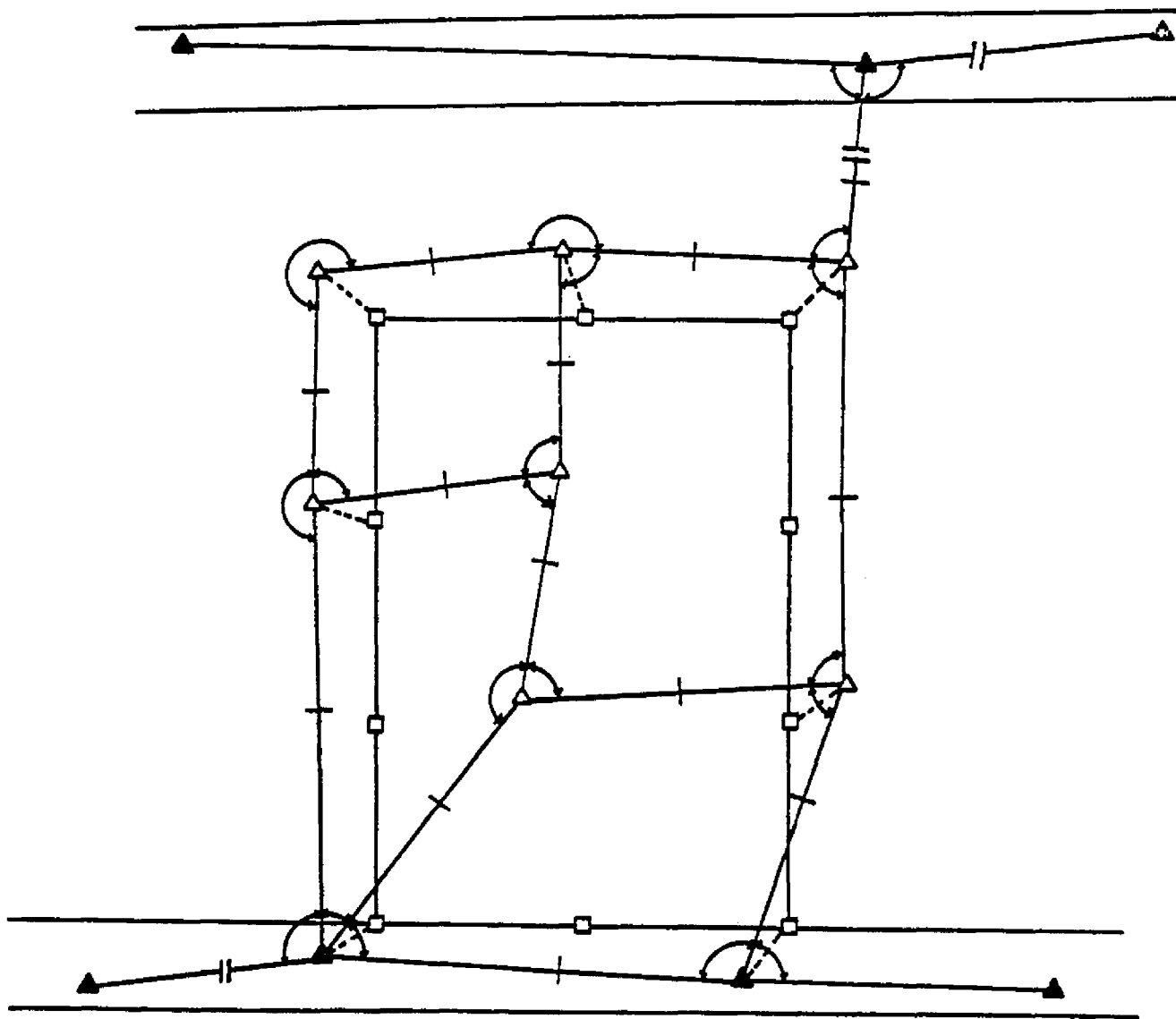



**GUIDELINES FOR USE OF TOTAL STATION AND RADIAL METHODS  
FOR LEGAL SURVEYS**

**PART I - MEASUREMENT**

1. All measurements, whether recorded manually or electronically, must be verified by mathematical closure or independent measurement.

Independent measurements shall include a. or b. and may include c. and d.

- a. The observation of all points from a minimum of two known points.
- b. Verification of all measurements by at least one redundant measurement to each observed point.
- c. The measurement of supplementary or closing angles.
- d. Distances measured in both forward and reverse directions.

**PART II - FIELD NOTES**

2. Field notes shall be comprised of:

- a) a sketch page showing;
  - (i) items 1.a) to 1.n) of the Guidelines for Field Notes
  - (ii) the lines run in the field
  - (iii) the evidence tied in
  - (iv) the point numbers which relate to the measurements recorded in the schedule of measurements or data stored in the data collector.
  - (v) direct check measurements.
- b) a record of corrective instructions, if any, to be applied to the data stored in the data collector.
- c) a schedule of measurements (manual) or computer printout of unedited raw data (electronic).
- d) a reference to the computer file where the data captured in the field is stored.

3. Items 2. to 7. of the Guidelines for Field Notes shall apply.

### **PART III - SURVEY RECORDS**

4. A permanent copy of the following shall be kept and will make up the survey records:
- a) field notes
  - b) an edited abstract of raw field data (computer printout) in a readable format.
  - c) a point plan which would;
    - (i) identify point numbers and what they represent
    - (ii) indicate the evidence accepted and the relationship of all evidence to the final boundary.
  - d) a coordinate list of all point numbers.

### **PART IV - EXAMPLES**

# EXAMPLE 1 - INDEPENDENT MEASUREMENTS

1. a)

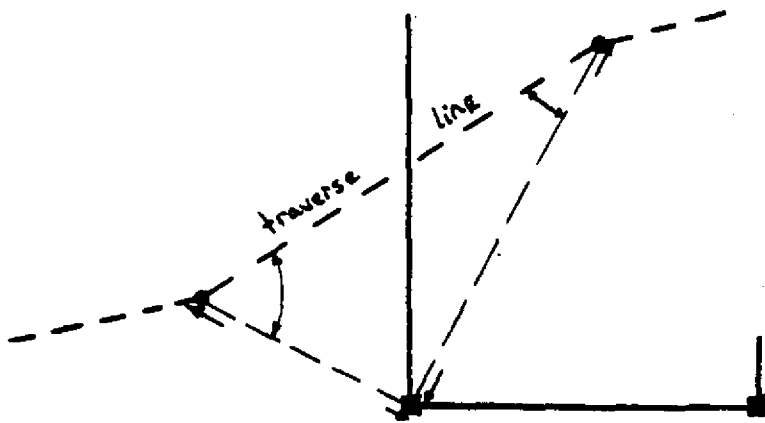

1. b)

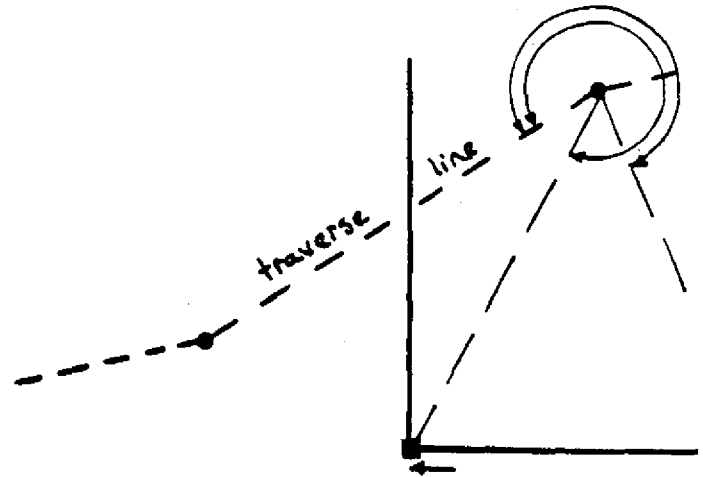

1. c)

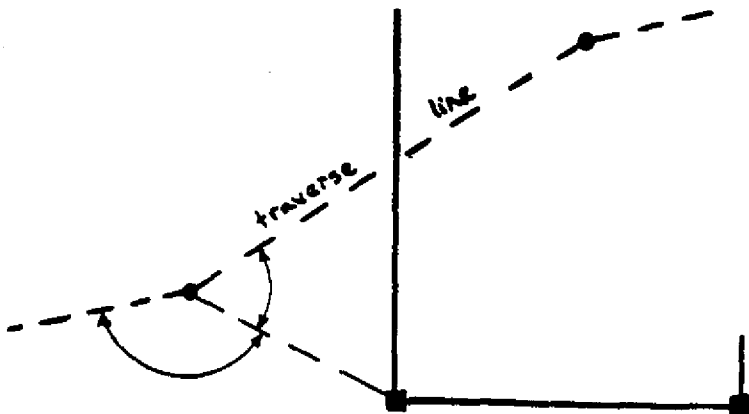

1. d)

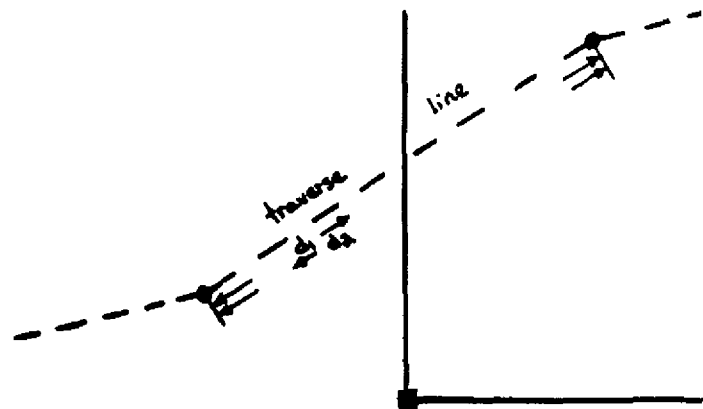

# EXAMPLE 2 - SKETCH PAGE

LOT Pt. 70    
 PLAN 593 YORK    
 TWP ETOBICOKE    
 COUNTY METROPOLITAN  
 BLOCK     CON.     CITY     REGION     TORONTO

BLK "B"

BLK "A"

M-16

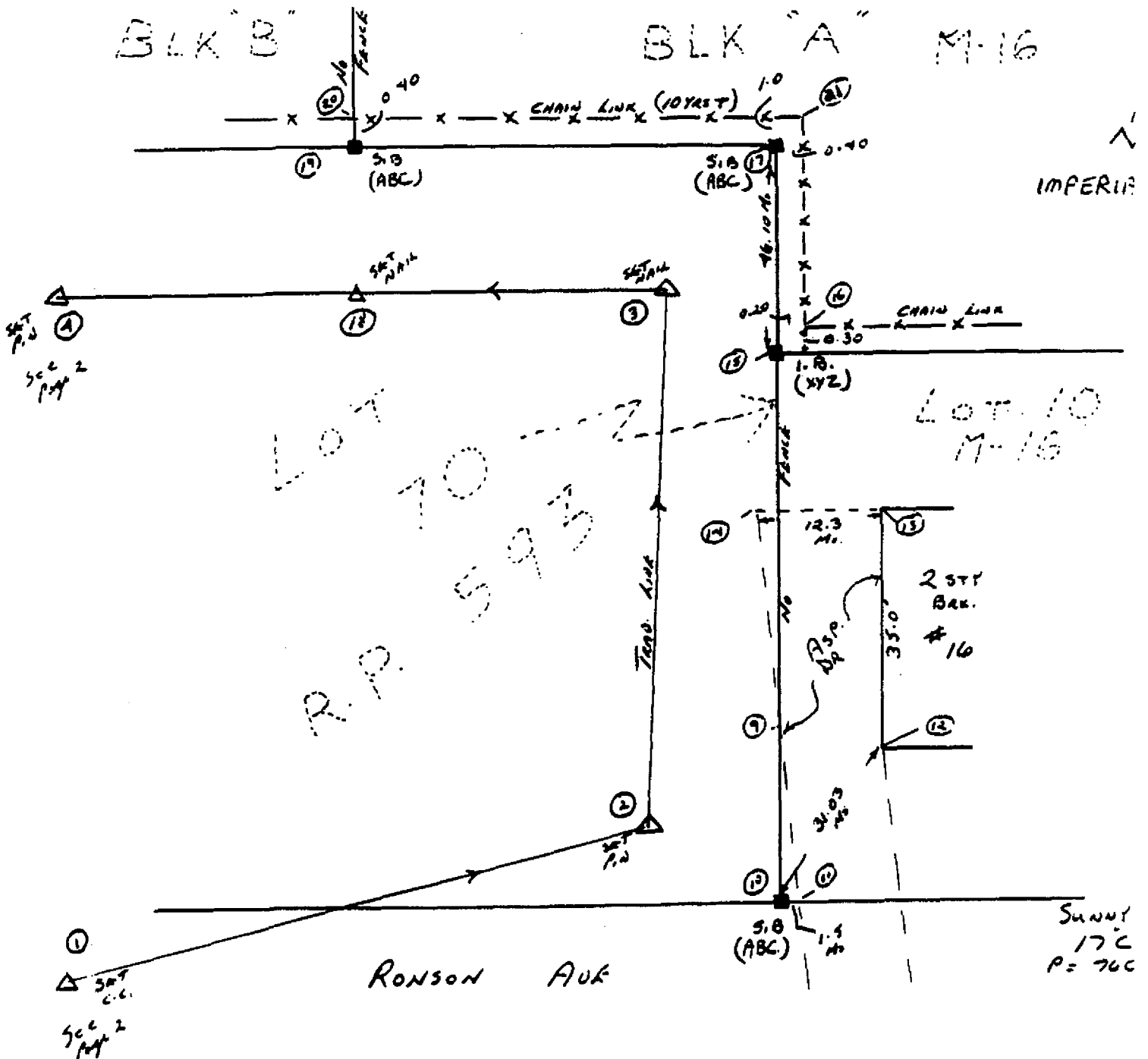

DATE SEPT. 1/90

PARTY J. DOE  
A. SMITH

FILE

90-285

### EXAMPLE 3 - CORRECTIVE INSTRUCTIONS

LOT Pt. Lot 70 PLAN 593 York TWP LETOBILONG COUNTY Metro Toronto  
BLOCK CON. CITY REGION

#### NOTES

- (1) Pt. (18) SET ON LINE BETWEEN (3) AND (4)
- (2) Pt. (15) ADD 0.30 TO DIST. FROM (3) (Pt. INACCESSIBLE (FENCE PO))
- (3) Pt. (15) I.B. (BLT) LEANS N.W. - 1 TIE IN TOP
- (4) DELETE Pt. 999 - SHOULD BE Pt. (9)

DATE SEPT. 1/90

PARTY J. DOE  
A. SMITH

FILE

90-285

# EXAMPLE 4 - SCHEDULE OF MEASUREMENTS (MANUAL)

LOT BLOCK A PLAN CON. M-252 TWP. CITY BRAMPTON COUNTY REGION PEEL

SEE SKETCH PAGE 1

$\pi$	BS	FS	ANGLE (DIRECT)	ANGLE (REVERSE)	DISTANCE (METRIC)	REMARKS
1	2		0-00-00	180-00-10	24.010	SIB (ABC)
		3	136-05-20	316-05-25	23.802	IB (ABC)
		4	130-39-30	310-39-40	33.664	IB (ABC)
		5	142-16-30	322-16-35	38.772	IB (ABC)
5	1		0-00-00	180-00-05		
		6	265-17-45	85-17-55	25.623	BRICK CORNER
		7	289-23-50	109-23-55	22.061	BRICK CORNER
		4	49-27-40	229-27-45	8.925	IB (CHECK)

DATE SEPT. 18/91

PARTY J. DOE  
A. SMITH

FILE

91-500

## EXAMPLE 5 - UNEDITED RAW DATA (ELECTRONIC)

### \*Raw Traverse Data

50=900925\80=1\51=25-09-1990\54=1\53=1230\56=17\74=760\  
80=2\2=2\4=411\62=1\21=0\7=.0002\11=122.043\4=411\  
80=3\7=.0024\11=122.046\  
80=4\5=100\7=3.0624\11=50.596\4=309\  
80=5\7=3.0622\11=50.595\  
80=6\5=101\7=32.2518\11=40.034\4=309\  
80=7\7=32.2504\11=40.028\  
80=8\5=102\7=52.4548\11=43.788\4=309\  
80=9\7=52.4536\11=43.788\  
80=10\5=103\7=15.492\11=9.481\4=309\  
80=11\7=15.4906\11=9.482\  
80=12\5=200\7=5.3616\11=9.013\4=136\  
80=13\7=5.3626\11=9.013\  
80=14\5=104\7=110.1528\11=6.134\4=309\  
80=15\7=110.1406\11=6.128\  
80=16\5=105\7=155.4924\11=10.339\4=309\  
80=17\7=155.4924\11=10.336\  
80=18\5=106\7=170.2008\11=10.027\4=309\  
80=19\7=170.2026\11=10.025\  
80=20\5=201\7=166.3708\11=10.453\4=135\  
80=21\7=166.3724\11=10.453\  
80=22\5=107\7=185.5802\11=12.835\4=155\  
80=23\7=185.5802\11=12.836\  
80=24\5=108\7=120.4758\11=15.261\4=309\  
80=25\7=120.4818\11=15.26\  
80=26\5=3\7=116.0012\11=35.471\4=411\  
80=27\7=116.0018\11=35.47\  
80=28\5=1\7=.0004\11=122.05\4=411\  
80=29\7=359.5946\11=122.046\  
80=30\2=3\4=411\62=2\21=0\7=.0004\11=35.466\4=411\  
80=31\7=359.5946\11=35.477\  
80=32\5=104\7=1.1344\11=29.388\4=309\  
80=33\7=1.1308\11=29.39\  
80=34\5=106\7=344.3822\11=30.718\4=309\  
80=35\7=344.3828\11=30.716\  
80=36\5=105\7=346.3038\11=28.311\4=309\  
80=37\7=346.3038\11=28.31\  
80=38\5=108\7=356.2654\11=20.312\4=309

# EXAMPLE 6 - EDITED ABSTRACT OF RAW FIELD DATA

SET TV 0001		No of Obs	023	
At	To	Direction	Hor. Dist.	Code
0001	0002	000-00-00	106.208	FD SBIB
0001	0003	346-58-35	153.667	FD IB
0001	0004	028-38-34	202.440	FD WS PL IB
0001	0005	044-41-12	188.443	FD WS
0001	0006	044-44-31	188.534	FD SIB
0001	0007	090-44-57	128.593	TOP FN M-1641
0001	0008	087-09-59	115.725	BTM 7TH BRK M-1641
0001	0009	091-29-37	190.060	SET NL
0001	0010	092-35-26	171.962	SDG M-1655
0001	0011	096-16-04	160.877	BTM BRK
0001	0012	097-44-32	157.907	BTM BRK
0001	0013	100-00-05	156.716	6 TH BRK M-1655
0001	0014	100-56-10	120.872	POLE
0001	0015	100-49-49	117.858	FD RB
0001	0016	099-40-50	128.107	GUY ANC
0001	0017	098-24-38	132.528	GUY ANC
0001	0018	109-53-11	146.250	GUY ANC
0001	0019	105-01-38	183.162	BTM BRK M-1655
0001	0020	129-33-56	260.155	SET NL
0001	0021	144-59-08	86.845	TOP FN LOT-9
0001	0022	267-58-41	57.761	13TH BRK M-2210
0001	0023	115-32-40	178.711	ASW
0001	0024	058-44-54	189.154	FD SIB





## EXAMPLE 8 - COORDINATE LIST

### Coordinate Listing

POINT	NORTHING	EASTING
1	5075.927	5095.709
2	4999.205	5000.801
3	4964.639	5008.753
4	4998.471	5101.336
100	5028.838	5041.810
101	5003.764	5040.569
102	4988.759	5043.325
103	5002.931	5009.520
104	4993.401	5002.768
105	4989.984	4996.131
106	4991.683	4994.174
107	4992.215	4990.035
108	4984.099	5002.966
109	5005.215	5104.287
110	5021.664	5101.317
111	5055.868	5095.172
112	5051.016	5096.027
113	5074.511	5091.842
200	5004.160	5008.330
201	4990.930	4994.414
202	5042.856	5056.026
250	5279.120	5249.793
251	4993.542	4992.099
252	4987.260	5043.600
253	4977.500	5010.615
254	4980.779	5021.157
255	4977.864	5011.060
256	5074.169	5091.903
257	5070.053	5092.641
258	5070.747	5092.517
259	4989.571	4996.569
260	4991.141	4994.785
261	4991.482	4994.400
262	4992.745	4992.985
263	5000.470	5005.525